

# SE-3000

## OPERATING INSTRUCTIONS

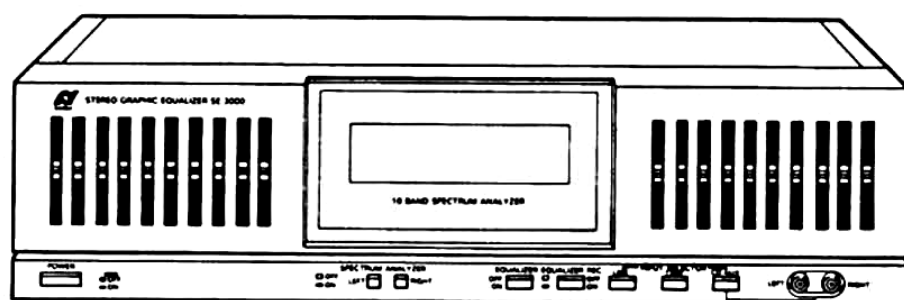

**CAUTION**RISK OF ELECTRIC SHOCK  
DO NOT OPEN

CAUTION: TO REDUCE THE RISK OF ELECTRIC SHOCK,  
DO NOT REMOVE COVER (OR BACK).  
NO USER-SERVICEABLE PARTS INSIDE.  
REFER SERVICING TO QUALIFIED SERVICE PERSONNEL.



The lightning flash with arrowhead symbol, within an equilateral triangle, is intended to alert the user to the presence of uninsulated "dangerous voltage" within the product's enclosure that may be of sufficient magnitude to constitute a risk of electric shock to persons.



The exclamation point within an equilateral triangle is intended to alert the user to the presence of important operating and maintenance (servicing) instructions in the literature accompanying the appliance.

---

**WARNING: To prevent fire or shock hazard, do not expose this appliance to rain or moisture.**

- The Model No. and Serial No. of your unit are shown on its back panel.
  - SANSUI attests that this product conforms with EEC directive 82/499/EEC.
-

Thank you for purchasing this fine SANSUI product. Taking the time to read these operating instructions carefully before use will acquaint you fully with all its features and help ensure optimum performance.

\* In order to simplify the explanation illustrations may sometimes differ from the originals.

## Precautions

### Power plug

When disconnecting the power cord from the power outlet, always take hold of the plug, and not the wire, and pull free. Never connect or disconnect the power plug with wet hands since you may receive an electric shock.

\* Remember to disconnect the power plug from the power outlet when you do not intend to use the unit for a prolonged period of time.

### Do not remove the case and bottom panel

Any inspections or adjustments inside the unit may lead to malfunctions and electric shocks. Do not touch any of the inside parts. SANSUI's warranty is not effective if a deterioration in the unit's performance results from remodeling inside.

### Installation precautions

Do not install the unit in any of the following locations since this may result in a deterioration in performance or malfunction:

- \* Locations exposed to direct sunlight or near objects radiating heat such as heating appliances.
- \* Locations exposed to moisture or humidity.
- \* Locations with poor ventilation exposed to dust and dirt.
- \* Locations which are unstable and not perfectly flat or which are susceptible to vibration.

### Do not wipe with thinners

Wipe the panels and case from time to time with a soft cloth. Using any kind of thinner, alcohol or volatile liquid will mar the surface, cause blotching on the exterior and erase the markings and should therefore be avoided.

Do not use insecticide sprays in the vicinity.

### AC OUTLET

Power is supplied to the AC OUTLET on the rear panel when the power cord is connected to a household AC outlet.

\* The maximum capacity of this outlet is 100 watts. Connecting an electrical appliance with a power consumption exceeding this rating is extremely dangerous. Check the rating before connection.

---

**NOTE:** Depending on the laws and regulation enforced locally, models without AC outlets may be supplied to some areas. Also, depending on the sales area, the shape of the AC outlets and their capacity may differ.

---

### Before connecting the power plug

Before connecting the power plug to an electrical outlet, check to be sure that the unit is set to the proper voltage for your area. If the voltage of the unit is improperly set, fire hazard or damage to the unit may result. If you find that the unit is not set to the proper voltage for your area, follow the instructions listed below:

- **Units with 120V/220V/240V VOLTAGE SELECTOR at rear panel**

These units are set at either 120V, 220V or 240V with the VOLTAGE SELECTOR. To change the voltage use a minus screwdriver to remove the plug, and reinsert it so that the mark (▲) matches the desired voltage.

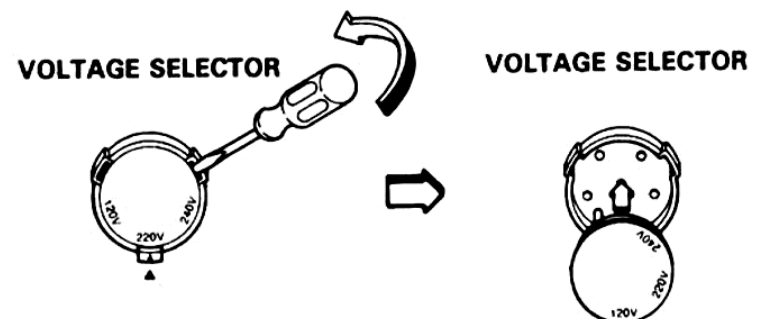

- **Units without voltage selector switch**

Units destined for some areas are not fitted with a voltage selector switch due to laws and regulations existing in those areas. In such a case, the power supply voltage is set to the voltage used in the area where the unit is purchased.

If the unit is to be used in an area where the power requirements are different, make sure you consult your nearest authorized SANSUI Service Station.

## Connections

\* Mains plug may vary to some extent depending on sales area, local laws and regulations.

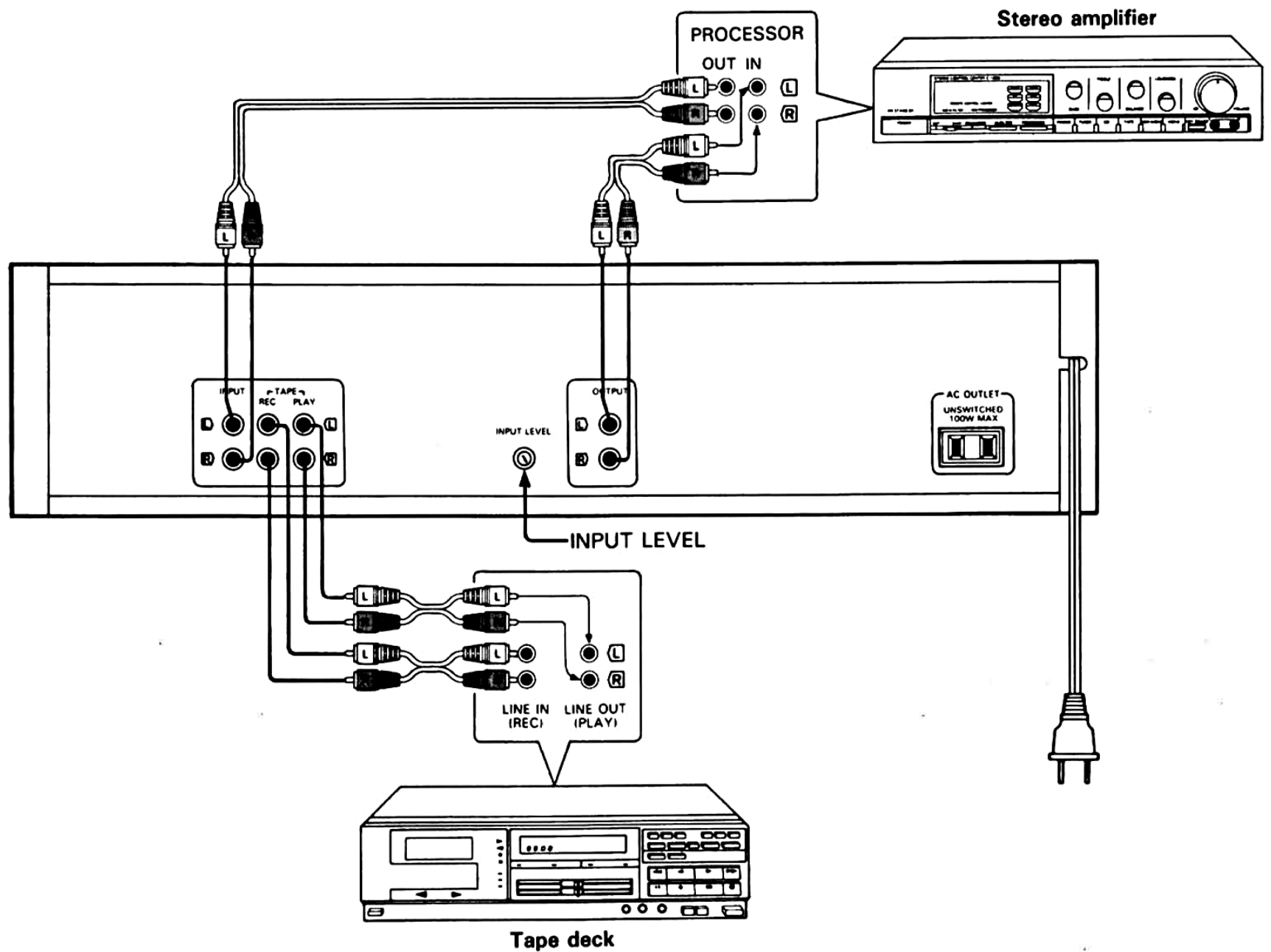

### Connection Precautions

- \* When connecting, either disconnect the power plug from the power outlet or turn off the unit's power using the POWER switch.
- \* Before connecting, read through the Operating Instructions of the other audio components which will be connected to this unit.
- \* Check the left and right channels and connect properly (L to L and R to R).
- \* Insert the plugs securely. Improper connection can lead to the generation of noise.

### Connecting unit to stereo amplifier

Using the pin-plug cord provided, connect the INPUT terminals of the unit to the PROCESSOR OUT terminals of the amplifier, and connect the OUTPUT terminals of the unit to the PROCESSOR IN terminals of the amplifier.

### Tape Deck Connections

Connect the TAPE REC terminals on the SE-3000 to the LINE IN/REC terminals on the tape deck and the TAPE PLAY terminals on the SE-3000 to the LINE OUT/PLAY terminals on the tape deck.

## Panel information

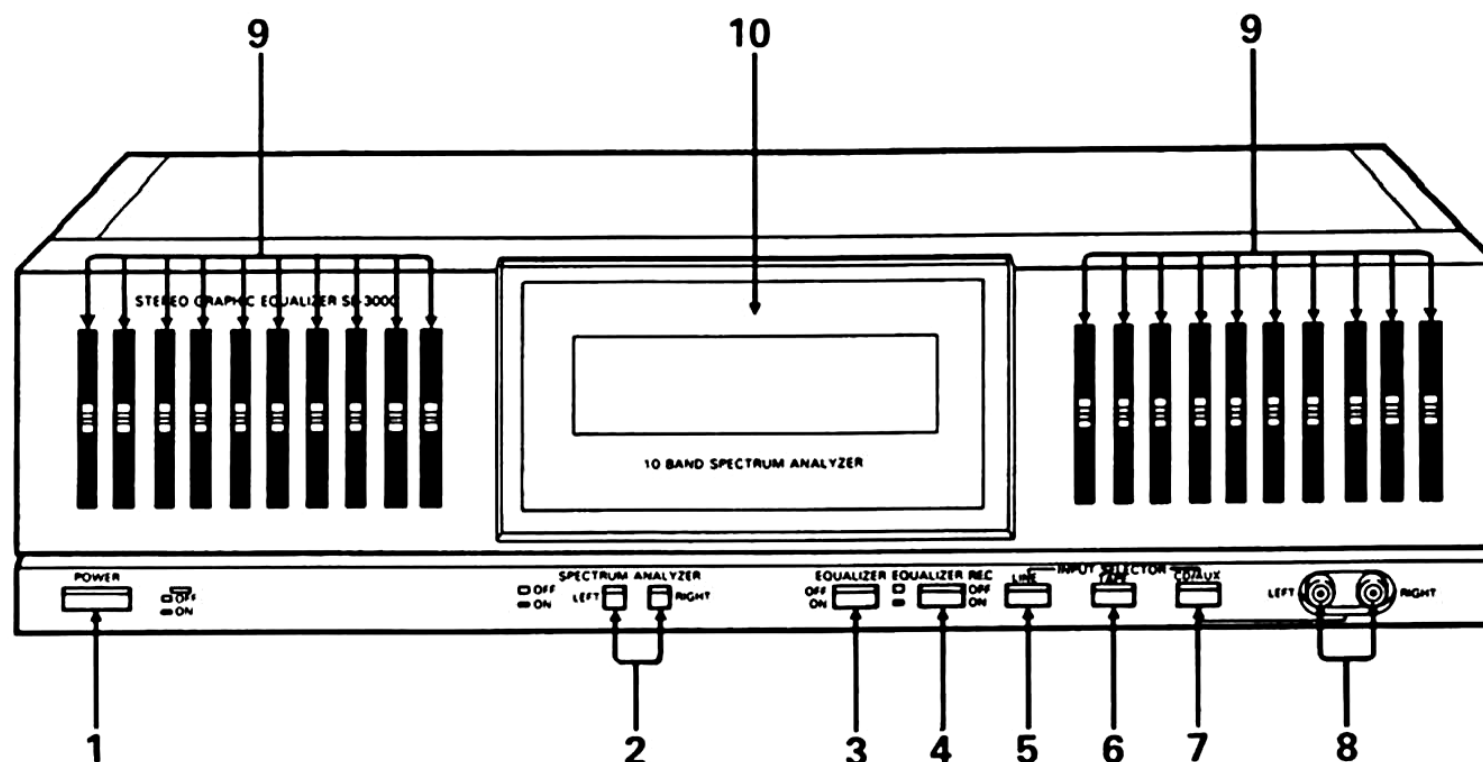

### 1 POWER Switch

Push the POWER switch once to turn the unit on, once more to turn it off.

### 2 SPECTRUM ANALYZER Switches

When the LEFT switch is set to ON, the spectrum analyzer indicates the frequency distribution of the left channel output. Set the RIGHT switch to ON in order to have the right channel frequency distribution indicated. Set both switches to ON to have the frequency distribution of both channels shown simultaneously.

### 3 EQUALIZER Switch

This switch is used to turn the equalizer circuit ON/OFF. Press it ON when you wish to apply frequency compensation to the reproduced sound. When you no longer wish to apply compensation, press this switch once again to turn it OFF. When the switch is OFF, flat frequency characteristics will be obtained regardless of the setting of the equalizer controls.

### 4 EQUALIZER REC Switch

Press this switch ON to apply compensation when recording on a tape deck connected to the unit.

When you no longer wish to apply compensation, press this switch once again to turn it OFF.

\* When this switch is ON, you can record a source with compensation even when the EQUALIZER switch is OFF.

### 5 LINE Switch

Press this switch when you wish to listen to a program source input via an amplifier (broadcast or record, etc.), or when you wish to record on a tape deck connected to this unit.

### 6 TAPE Switch

Press this switch when you wish to play a tape on tape deck connected to this unit.

### 7 CD/AUX Switch

Press this switch when you wish to operate a compact disc player connected to the input terminals on the right of this switch, or when recording on a tape deck connected to this unit.

### 8 CD/AUX Input Terminals

By connecting these terminals to the audio output terminals of a compact disc player or VCR, then pressing the CD/AUX switch, you can play the source connected to these terminals.

### 9 Equalizer Level Controls

These controls allow the levels approximate to the frequencies indicated below the controls to be continuously controlled from +12 dB to -12 dB for the left and right channels separately.

The level is made flat when the controls are set to the center "0" position. The level is increased when the controls are slid up from this center position and decreased when they are slid down. Adjust each of the frequency levels to your preference or requirements.

\* You can apply compensation to the reproduced sound only when you press the EQUALIZER switch ON.

### 10 SPECTRUM ANALYZER Display

This divides the frequency band into 10 parts, and it indicates the level of the output signal into each band. This display makes it possible to monitor the frequency distribution of the output signals at a glance.



## Operating procedures

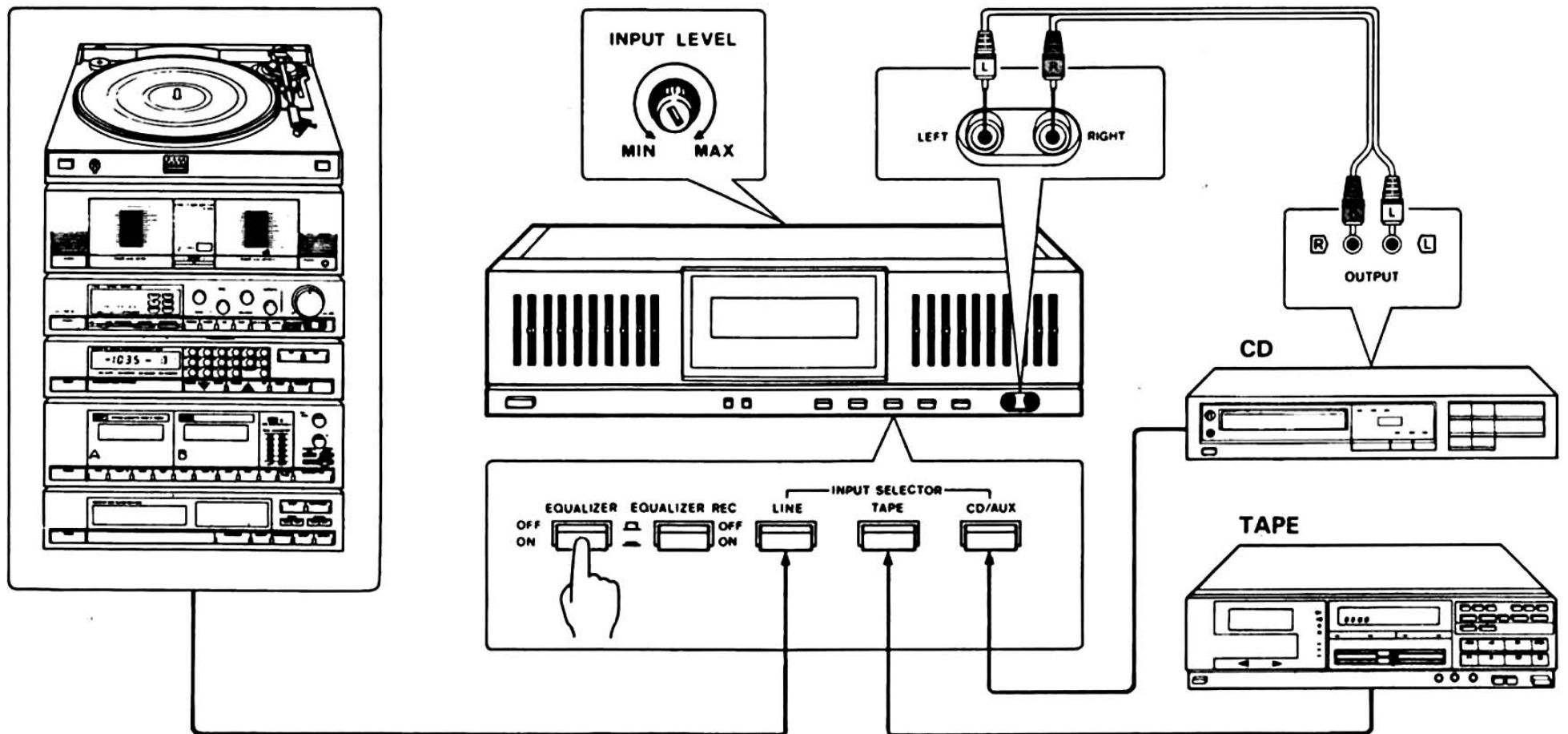

### Before starting operation

Set the PROCESSOR switch of the stereo amplifier connected to this unit to ON.

### Playing a program source with added equalizer effects

This unit can be used to achieve subtle frequency compensation which is not possible using the tone controls or filters of amplifier.

You can not only compensate for fluctuations in the frequency response produced by the shape of the listening room and cut out the undesirable frequencies but also color the sound of the program source as desired. In other words, this unit gives you complete control over the sound.

1. Switch ON the unit.
2. **When listening to a record or radio broadcast:** Press the LINE switch, select the desired program source using the selector switch on the amplifier, then operate the turntable or tuner.
3. **Playing a tape:** To play back a tape in a tape deck connected to this unit, press the TAPE switch and then operate the tape deck in the playback mode.
4. **Playing a compact disc:** To play a compact disc in a compact disc player connected to the terminals on the front panel, press the CD/AUX switch and then put the compact disc player in the play mode.
5. Adjust the sound level using the VOLUME control on the amplifier.
6. To apply frequency compensation, press the EQUALIZER switch ON.
7. Use the equalizer level controls to adjust the sound quality of the reproduced source to you preference.

### INPUT LEVEL Control

When a compact disc is being played, an excessively large input may sometimes be applied to this unit, causing the indication on the spectrum analyser to exceed the upper limit. In such a case, rotate the INPUT LEVEL control at the back of the unit until the reproduced sound is undistorted and the indication on the spectrum analyser can be easily seen.

- \* Note that if you set the INPUT LEVEL control to MIN, you cannot perform playback using this unit.
- \* Note that if you adjust the INPUT LEVEL control, the recording output level will also change.

### Effectiveness of equalizer for each frequency band

**32 Hz to 125 Hz:** You can accentuate very low frequencies such as from a bass drum or pipe organ, or compensate for a lack of bass when listening at a low volume level or using a small speaker.

**125 Hz to 250 Hz:** Raise the volume level in this band when you wish to accentuate mid-range frequencies such as the sound of a saxophone. Also, if you are listening in a room where the low frequencies tend to sound heavy, try reducing the level in this band.

**500 Hz to 1 kHz:** This band covers the basic frequency range of almost all musical instruments.

You can control the forcefulness or sharpness of the sound.

**1 kHz to 2 kHz:** By controlling the volume level in this range you can accentuate or moderate vocal passages. Also, by lowering the volume level at 2 kHz, the resulting sound will be mild and easy to listen to.

**4 kHz to 8 kHz:** By raising the volume level in this band, you can increase the brilliance of cymbals, trumpets, and other brass instruments.

**8 kHz to 16 kHz:** By raising the volume level in this band you can add luster to cymbals and triangles, and produce a spread approaching that of a live stage or concert hall.

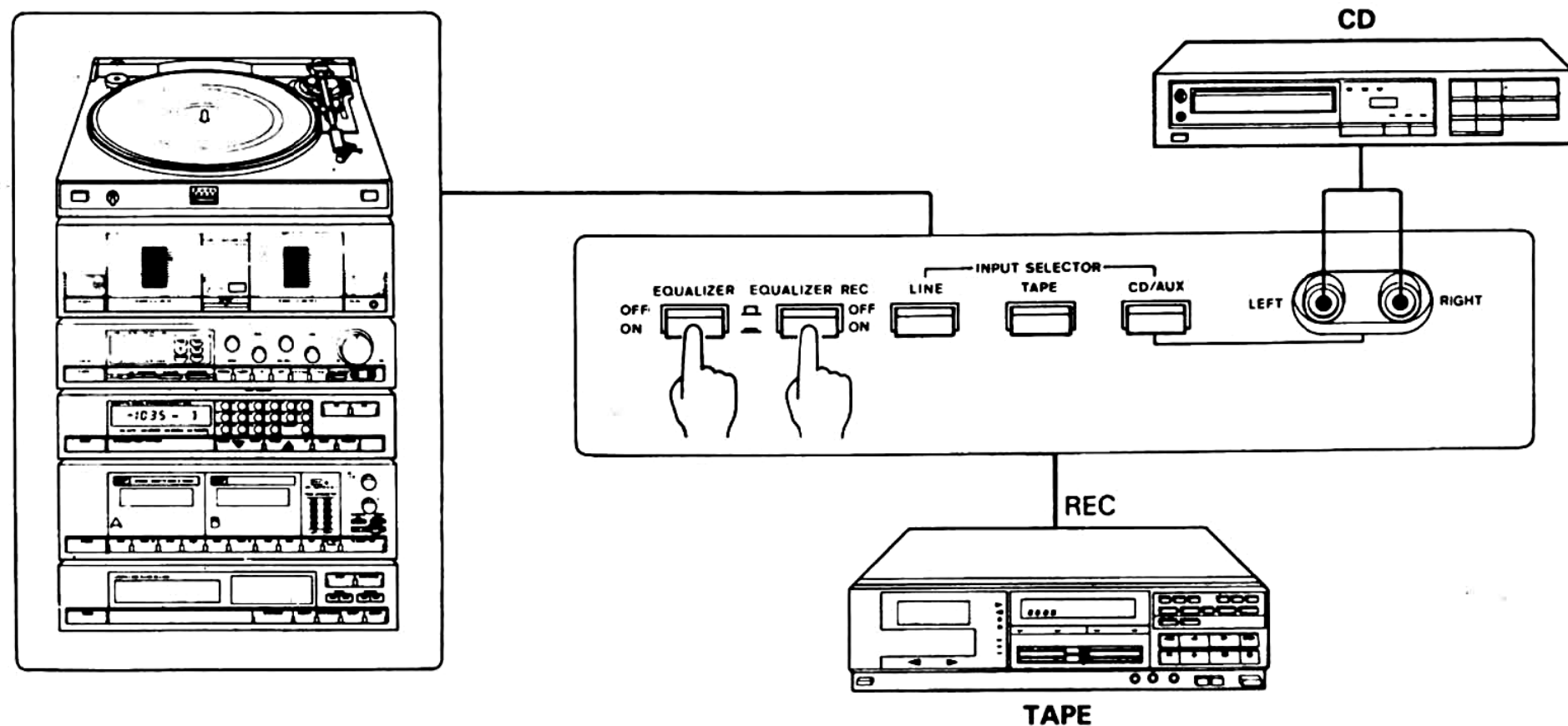

### Tape recording with sound quality adjustment

1. When recording a LINE input program source (record or radio broadcast, for example), set the INPUT SELECTOR switch to LINE.
  2. When recording a CD/AUX input program source, set the INPUT SELECTOR switch to CD/AUX.
  3. To change the sound quality, press the EQUALIZER and EQUALIZER REC switches, then play back the program source and adjust the sound quality as desired.
  4. Set the tape deck in the recording mode, adjust the recording level, and commence recording.
- \* If you apply additional equalizing when playing back a tape which was recording with equalizing, the level may increase to the extent that distortion occurs.

## Example of adjusting graphic equalizer controls

### For pop music

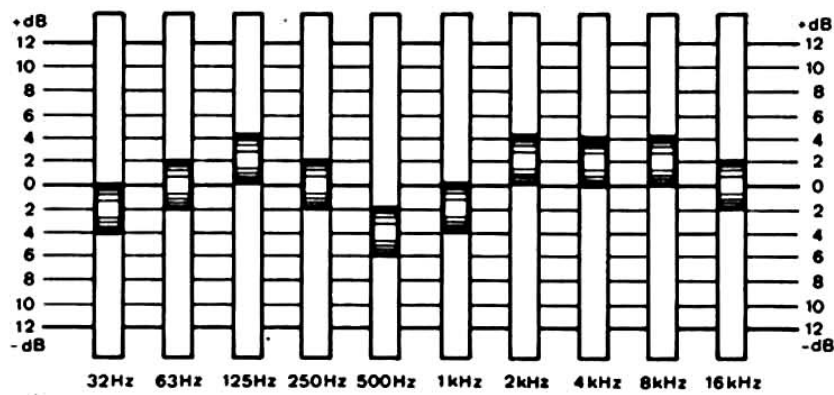

### For car audio

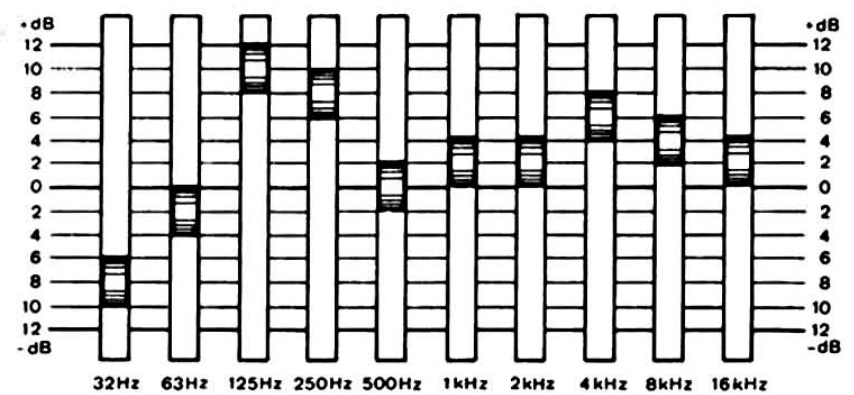

### For classical and easy listening music

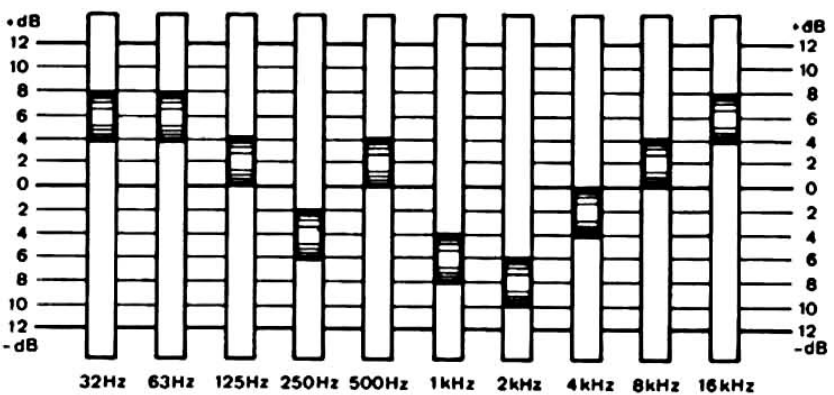

### For headphone stereo

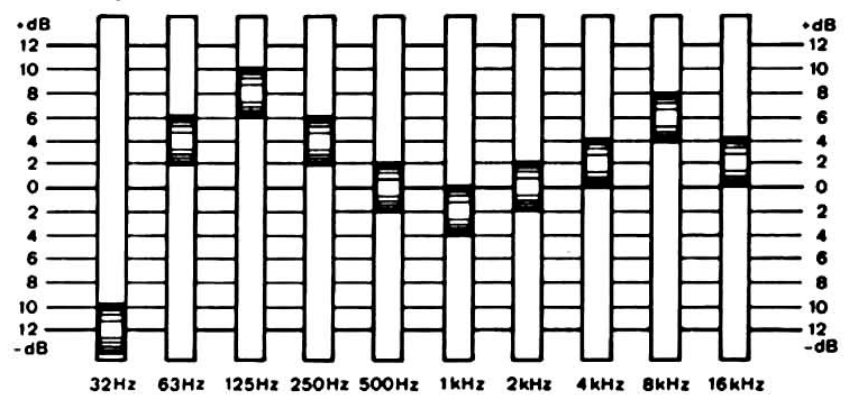

### For rock music

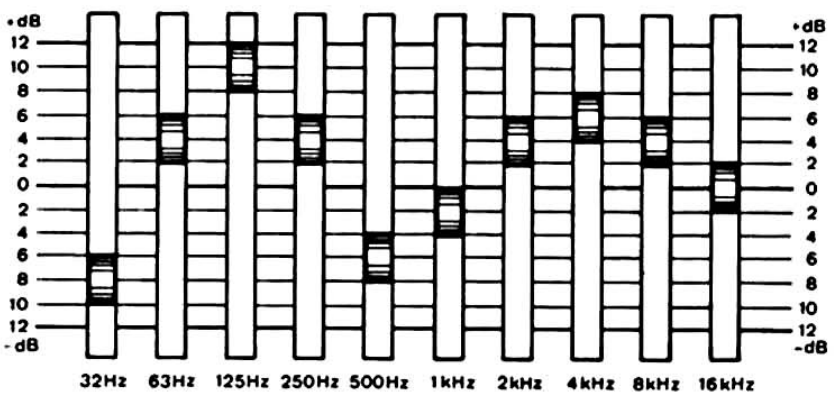

## Specifications

### Input sensitivity and impedance (1 kHz)

INPUT, TAPE PLAY ..... 150mV/47 kohms

### Output level and impedance (1 kHz)

TAPE REC ..... 150mV/4.7 kohms

OUTPUT ..... 150mV/4.7 kohms

(Maximum output level: 5V into 47 kohms at 0.5% total harmonic distortion)

### Total harmonic distortion (2V, 20 Hz to 20 kHz)

INPUT, TAPE PLAY ..... 0.008%

### Frequency response (at 0.5V, Equalizer controls: "0" position)

INPUT, TAPE PLAY ..... 10 Hz to 100 kHz,  
+0 dB, -1.0 dB

### Signal to noise ratio (Short-circuit, A-network)

INPUT, TAPE PLAY ..... 110 dB

Equalizer frequency ..... 32 Hz, 63 Hz, 125 Hz,  
250 Hz, 500 Hz, 1 kHz,  
2 kHz, 4 kHz, 8 kHz, 16 kHz,

Level variation range .....  $\pm 12$  dB

### Others

Power voltage ..... 120, 220, 240 V  
(50/60 Hz)

For U.S.A. and Canada ..... 120 V (60 Hz)

Power consumption ..... 17 watts

Dimensions ..... 430 mm (16-15/16") (W)  
112 mm (4-7/16") (H)  
223 mm (8-13/16") (D)

Weight ..... 3.1 kg (6.8 lbs) net  
4.05 kg (8.9 lbs) packed

\* Design and specifications subject to change without notice for improvements.

\* Due to local laws and regulations, this unit sold in some areas are not equipped with variable voltage selectors.



SANSUI

SANSUI ELECTRIC CO., LTD.

14-1 Izumi 2-Chome, Sugunami-ku, TOKYO 168, JAPAN

Printed in Japan (28M1) <49040800>